

KPS-DCAC-220

110Vdc, 115Vdc, 127Vdc

DC/AC SINUSOIDAL INVERTER

Description:

Sinusoidal output voltage

Selectable frequency: 50/60Hz

High input/output isolation: 3000Vrms

Remote deactivation

Input and output alarm (optional)

Optional railway version: EN50155, RIA12

Fire and smoke protection: EN45545-2



Features:

Input :

24Vdc, 48Vdc, 72Vdc,
110Vdc, 127Vdc

Output: Sinusoidal

115Vac / 230Vac 50Hz
180 to 220 W



Possible version :

	12Vdc 9.5 ... 15V	24Vdc 16.8 ... 30V	36Vdc 25.2 ... 45V	48Vdc 33.6 ... 60V	72Vdc 50.4 ... 90V	110Vdc 77 ... 138V
120Vac	180W	200W	220W	220W	220W	220W
230Vac	180W	200W	220W	220W	220W	220W

Technical specification :

INPUT	
Input voltage range	See table
Maximum input ripple	5% $V_{in\ nom}$ (V_{rms} , 100Hz)
OUTPUT	
Nominal output voltage (V_{onom})	See table
Adjust range	$\pm 5\%$ of V_{onom}
Load regulation	4%
Line regulation	0.4% @ $\Delta V_{in} -20\dots+25\%$ 10% @ $\Delta V_{in} -30\dots+25\%$ 1% @ $\Delta V_{in} -10\dots+25\%$ for 12V input models 10% @ $\Delta V_{in} -20\dots+25\%$ for 12V input models
Output frequency	50 / 60Hz ± 0.25 Hz
Output wave distortion THD	< 2% (16 samples average)
Output voltage HF ripple (BW: 20Mhz)	< 20Vpp for 230Vac models < 10Vpp for 120Vac models
ENVIRONMENTAL	
Storage temperature	-40 ... 80°C
Operating temperature (full load)	-40 ... 55°C
Operating temperature (62.5% load)	-40 ... 70°C
Cooling	Natural convection
Shock and vibration	According to EN61373:2010
MTBF (MIL-HDBK-217-E; G_b , 25°C)	250.000 h
EMC	
Immunity according	EN61000-6-2 EN50121-3-2
Emissions according	EN61000-6-4 EN50121-3-2
SAFETY	
Safety according to	EN60950-1, EN62368-1 Class I OV category II, Pollution degree 2 Input / output isolation: reinforced
Dielectric strength: Input / output	3000 V_{rms} / 50Hz / 1min (routine test 2s)
Dielectric strength: Output / ground	1500 V_{rms} / 50Hz / 1min (routine test 2s)
Dielectric strength: Input / ground	1000 V_{rms} / 50Hz / 1min (routine test 2s)
Fire and smoke	EN45545-2
MECHANICAL	
Weight	900 g
Dimensions	100 x 220 x 40mm
PROTECTIONS	
Against input over-currents	Internal fuse
Against output overloads < I_{ompk}	linear
Against output overloads > I_{ompk}	Triggered
CONTROL	
Remote inhibit input	4 ... 24 Vdc
Output failure alarm	Solid state relay, open when alarm. Max: 60V, 0.3A

Block Diagram :

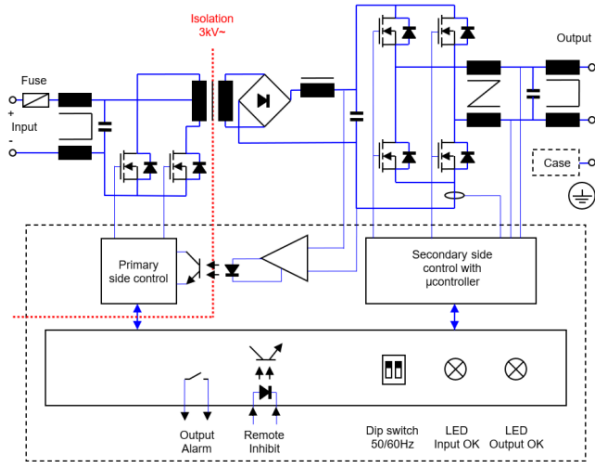

Connections :

Connector DIN41612H15 (Max. 12A / terminal)

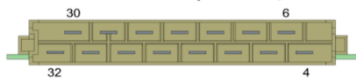

Spring clamp terminals (Max. 12A / terminal)



CONNECTION	Terminal
-Vin	2, 4, 6
+Vin	8, 10
-Inhibit	12
+Inhibit	14
-Alarm	16
+Alarm	18
N	22, 24
L	28, 30
PE	32

Description :

The KPS-DCAC-220 is a 120Vac or 230Vac sinusoidal output inverter with a frequency of 50Hz or 60Hz.

The inverter features galvanic isolation between the input and output.

The KPS-DCAC-750 inverter is built around two cascaded converters. The first DC-DC converter provides an intermediate voltage from the input voltage. This intermediate voltage is inverted, and the DC-AC converter provides the output voltage and frequency.

The input is protected against reverse polarity by a fuse and against input undervoltage by shutting down the unit.

The output is protected against overcurrent and overshoot. The unit shuts down if it exceeds the operating limits for more than one second. Every 2 seconds after shutdown, the unit attempts to restart up to 3 times. If the fault persists, the unit remains off until the input is reconnected.

Installation :

There are two connecting options: spring clamp terminal strip and DIN-41612-H15 connector. The product can be mounted in several ways:

- On a chassis by means of the 4 corner holes.
- In EUROCARD racks. For this application there is a standard 10Te front plate accessory NP-9289
- With the mounting base NP-9125.

This accessory can be mounted on a chassis or in DIN rail adding the clip accessory NP-9135. Make connections as shown in the CONNECTIONS table. The default output frequency is 50Hz. For 60Hz simply actuate the dip-switch as indicated in the figure.

The inverter includes active overload protection but does not provide protection against prolonged reactive overload conditions. Therefore, the maximum power output (VA) should not be exceeded.

For safety reasons, the following requirements must be met:

- Provide the equipment with some kind of protective enclosure that complies with the electrical safety directives in effect within the country where the equipment is installed.

- Use cables of adequate cross-section to connect inputs and outputs. The following table lists the maximum currents and the minimum cross-sections for the cables used for each power connection.

	Input 12V	Input 24V	Input 36V	Input 48V	Input 72V	Input 110V	Output 120Vca	Output 230Vca
Max. Current [A]	23	14	10	7.4	5.0	3.2	2.2	1.2
Cable Section [mm ²]	2.5	1.5	1.5	1	0.75	0.75	0.75	0.75

POWER DERATING vs AMBIENT TEMP.

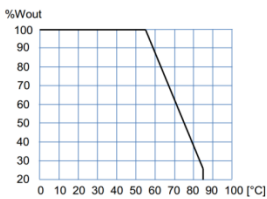

OPERATION CURVE LIMITS

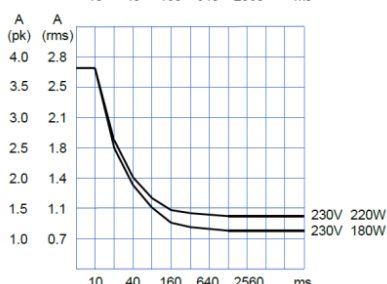
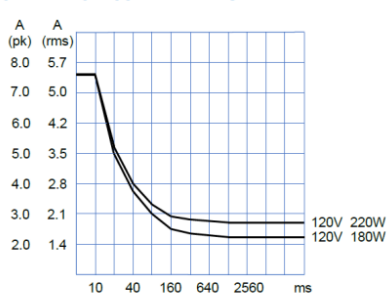

Dimensions :

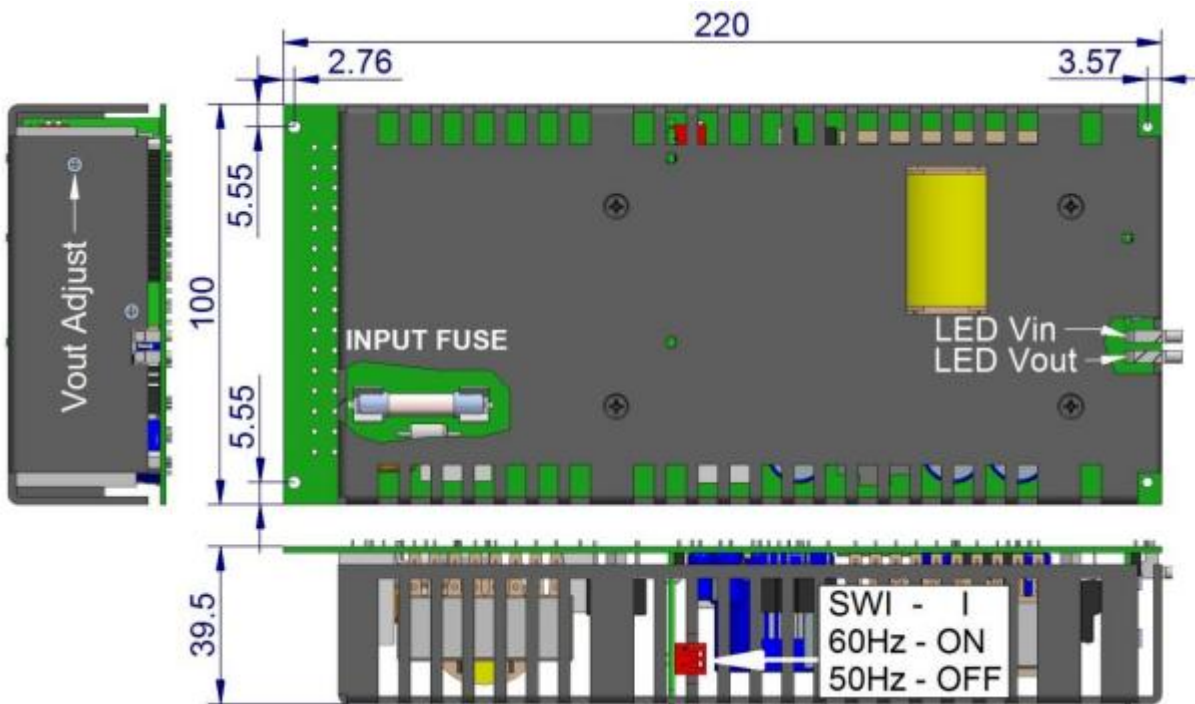

Accessoires :

ACCESSORIES	NOTES
Mounting base	Screws included
DIN RAIL CLIP for mounting base	Screws included
Front plate 19" subrack (3U 10TE)	Screws and LED light guides included
FR4 PCB solder side cover protection	Screws included

